

鎢鋼 4刃內R 倒角立銑刀

TUNGSTEN CARBIDE 4-FLUTE INTERNAL R CHAMFERING END MILL

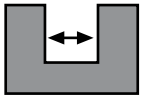

$d \leq 3$ -0.005 ~ -0.028
 $3 < d \leq 6$ -0.015 ~ -0.038
 $6 < d \leq 18$ -0.020 ~ -0.047
 $18 < d$ -0.020 ~ -0.053

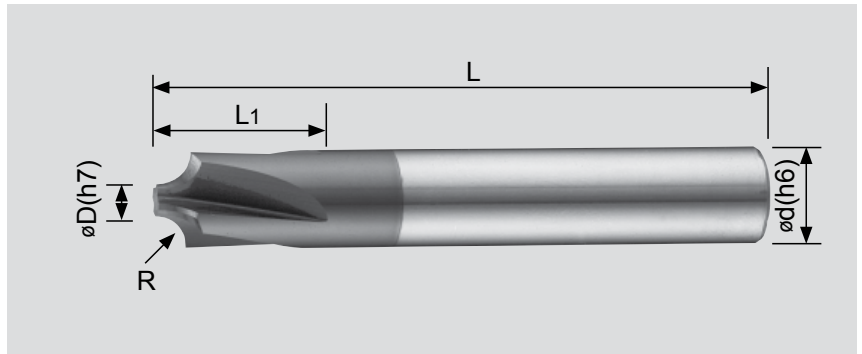

- 超細微粒碳化鎢材質
- Micro-Grain Tungsten Carbide

適合材質：

碳素鋼、模具鋼、合金鋼、工具鋼、
不鏽鋼、鑄鐵、熱處理鋼料、焊補鋼料。

Applicable material:

Carbon steel, mold steel, alloy steel, tool steel,
stainless steel, cast iron, heat-treated steel, welded steel.

單位: Unit : mm

型號 EDP NO.	刃徑 D Flute Dia.	R 徑 Radius	刃長 L1 Length of Cut	全長 L Overall Length	柄徑 d Shank Diameter	Ds 徑 Flute Flute Dia	刃數 Flute Number	AK45	AK925
4EIR-D6.0L50-R10	6.0	R 1.0	9	50	6.0	4.0	4	●	●
4EIR-D6.0L50-R15	6.0	R 1.5	9	50	6.0	3.0	4	●	●
4EIR-D8.0L60-R20	8.0	R 2.0	12	60	8.0	4.0	4	●	●
4EIR-D10.0L75-R25	10.0	R 2.5	15	75	10.0	5.0	4	●	●
4EIR-D10.0L75-R30	10.0	R 3.0	15	75	10.0	4.0	4	●	●
4EIR-D12.0L75-R40	12.0	R 4.0	24	75	16.0	4.0	4	●	●
4EIR-D16.0L100-R50	16.0	R 5.0	24	100	16.0	6.0	4	●	●
4EIR-D20.0L100-R60	20.0	R 6.0	30	100	20.0	8.0	4	●	●

註: 有●者表示有庫存

NOTE: ● means items in stock

切削條件表請參考第90頁